

0100 SKY LASER LIGHT PRODUCT MANUAL

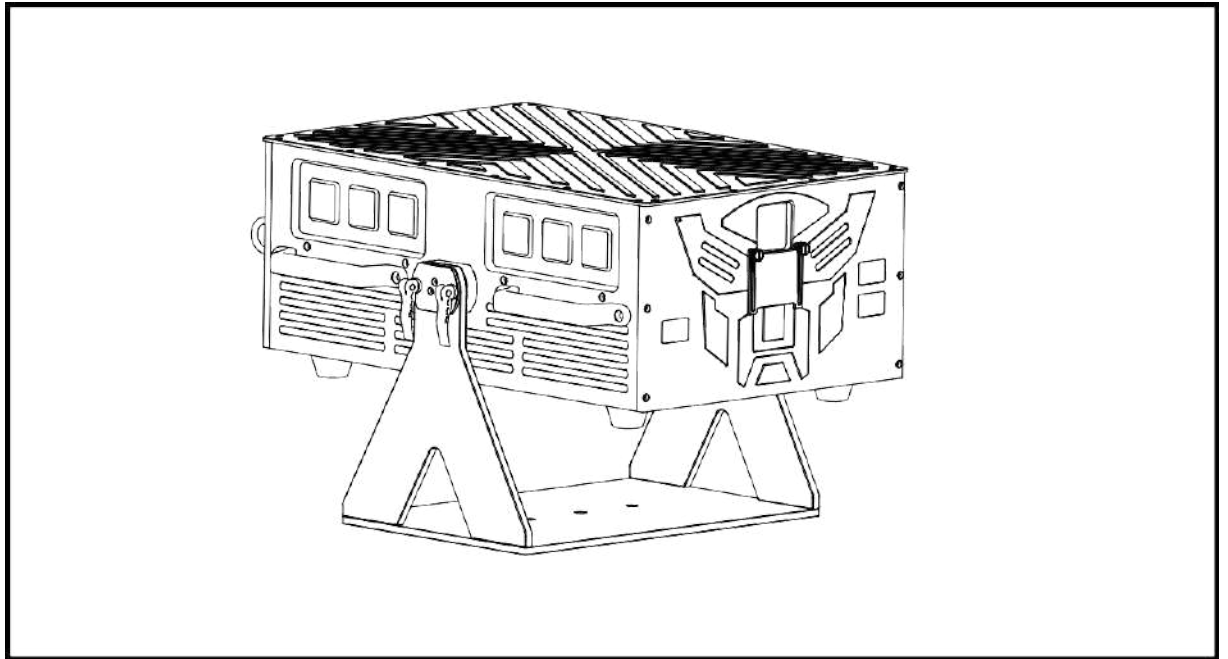

Thank you for purchasing our products, please take some minutes to read this manual before operating any of these laser projectors!

www.starshinelights.com

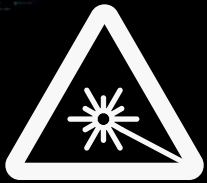

STARSHINE LIGHTS
PRODUCT MANUAL



INTRODUCTION

Thank you for purchasing our products. To optimize the performance of your laser, please read these operating instructions carefully and familiarize yourself with the basic operations of this system. These instructions contain important safety information regarding the use and maintenance of this system as well. Please keep this manual with the unit, for future reference. If you sell this product to another user, be sure that they also receive this document.

Notice

- We are constantly striving to improve the quality of our products. As such, the content of this manual may be changed without notice.*
- We have tried our best to guarantee the accuracy of this manual. If you have any questions or find any errors, please contact us directly to help correct this.*

PACKING LIST

Name	Qty(pcs)
LASERprojector	1
ACpowercord	1
KeysforKeyswitch	2
Poweroutputconnector	1
RemoteInterlock connector	2
Allenkey	1

UNPACKING INSTRUCTIONS

Open the package and carefully unpack everything inside.

Ensure all parts are present and in good condition.

Do not use any equipment that appears to be damaged.

If any parts are missing or damaged then please immediately notify your carrier or local distributor.

GENERAL INFORMATION

The following chapters explain important information about lasers in general, basic laser safety and some tips about how to use this device correctly. Please read this information as it contains critical information you must be aware of, prior to using these system.

SAFETY NOTES

WARNING! These projectors are Class 4 laser products. It must never be used for audience-scanning applications. The output beam of the projector must always be at least 3 meters above the floor in the audience. See the Operating Instructions section for further information. Please read the following notes carefully! They include important safety information about the installation, usage, and maintenance of this product.

- **Keep this User Manual for future consultation. If you sell this product to another user, be sure that they all receive this document.**
- **Always make sure that the voltage of the outlet to which you are connecting this product is within the range stated on the decal or rear panel of the product.**
- **This product is not designed for use outdoors in adverse weather conditions. To prevent risk of fire or shock, do not expose this product to rain or moisture.**
- **Always disconnect this product from the power source before cleaning it or replacing the fuse. Make sure to replace the fuse with another of the same type and rating.**
- **If mounting it overhead, always secure this product to a fastening device using a safety chain or cable. In the event of a serious operating problem, stop using the projector immediately. Never try to repair the unit except in a controlled environment under trained supervision. Repairs carried out by unskilled people can lead to damage or malfunction of the unit, as well as exposure to dangerous laser light.**
- **Never connect this product to a dimmer pack.**
- **Make sure the power cord is not crimped or damaged.**
- **Never disconnect the power cord by pulling or tugging on the cord.**
- **Never carry a product from the power cord or any moving part. Always use the hanging/mounting bracket handles.**
- **Always avoid eye or skin exposure to direct or scattered light from this product.**
- **Lasers can be hazardous and have unique safety considerations. Permanent eye injury and blindness is possible if lasers are used incorrectly. Pay close attention to each safety REMARK and WARNING statement in this user manual. Read all instructions carefully BEFORE operating this device.**
- **Never intentionally expose yourself or others to direct laser light.**
- **This laser product can potentially cause instant eye injury or blindness if laser light directly strikes the eye.**
- **It is illegal and dangerous to shine this laser into audience areas, where the audience or other personnel could get direct laser beams or bright reflections into their eyes.**
- **It is a US Federal offense to shine any laser at aircraft.**
- **No service allowed by customer. There are no user serviceable parts inside the unit. Do not attempt any repairs yourself.**
- **Service is only to be handled by the factory or authorized factory trained technicians. Product is not to be modified by the customer.**
- **Caution – use of controls or adjustments or performance of procedures other than those specified herein may result in hazardous radiation exposure.**

LASER AND SAFETY NOTES STOP AND READ ALL THE LASER SAFETY NOTES BELOW

Laser Light is different from any other light sources with which you may be familiar. The light from this product can cause eye and skin injury if not set up and used properly. Laser light is thousands of times more concentrated than light from any other kind of light source. This concentration of light can cause instant eye injuries, primarily by burning the retina (the light sensitive portion at the back of the eye). Even if you cannot feel “heat” from a laser beam, it can still potentially injure or blind you or your audience. Even very small amounts of laser light are potentially hazardous even at long distances. Laser eye injuries can happen quicker than you can blink. It is incorrect to think that because these laser entertainment products use high speed scanned laser beams, that an individual laser beam is safe for eye exposure. It is also incorrect to assume that because the laser light is moving, it is safe. This is not true. Since eye injuries can occur instantly, it is critical to prevent the possibility of any direct eye exposure. It is not legal to aim this laser projector into areas where people can be exposed. This is true even if it is aimed below people’s faces, such as on a dance floor.

- *Do not operate the laser without first reading and understanding all safety and technical data in manual.*
- *Always set up and install all laser effects so that all laser light is at least 3 meters (9.8 feet) above the floor on which people can stand. See the “Proper Usage” section later in this manual.*
- *After set up, and prior to public use, test the laser to ensure proper function. Do not use if any defect is detected.*
- *Laser Light - Avoid Eye or Skin Exposure to Direct or Scattered Light. • Do not point lasers at people or animals.*
- *Never look into the laser aperture or laser beams.*
- *Do not point lasers in areas where people can potentially be exposed, such as uncontrolled balconies, etc.*
- *Do not point lasers at highly reflective surfaces, such as windows, mirrors and shiny metal objects. Even laser reflections can be hazardous.*
- *Never point a laser at aircraft, as this is a US Federal offense. • Never point un-terminated laser beams into the sky.*
- *Do not expose the output optic (aperture) to cleaning chemicals.*
- *Do not use the laser if the housing is damaged, open, or if the optics appear damaged in anyway. • Never leave this device running unattended.*
- *In the United States, this laser product may not be purchased, sold, rented, leased or loaned for use unless the recipient possesses a valid Class 4 laser light show variance from the US FDA CDRH.*
- *This product must always be operated by a skilled and well-trained operator who is familiar with the data included in this manual. Note that use of this projector in the United States also requires a valid Class 4 laser light show variance from the CDRH as stated above.*

-
- *The legal requirements for using laser entertainment products vary from country to country. The user is responsible for the legal requirements at the location/country of use.*
 - *Always use appropriate lighting safety cables when hanging this projector overhead.*

IMPORTANT: More Safety Information

Background information

While eye exposure is the main concern, high-powered lasers can also cause skin burns. Most laser scanning devices used in industries were low-powered a few decades ago and didn't pose a significant risk, but it's still important to handle them with care. Nowadays, more and more show lasers in the show industry are high-powered even up to several hundred Watts, which equires operators to pay great attention to the safety of using these products.

Regular maintenance and proper usage can help prevent accidental exposure.

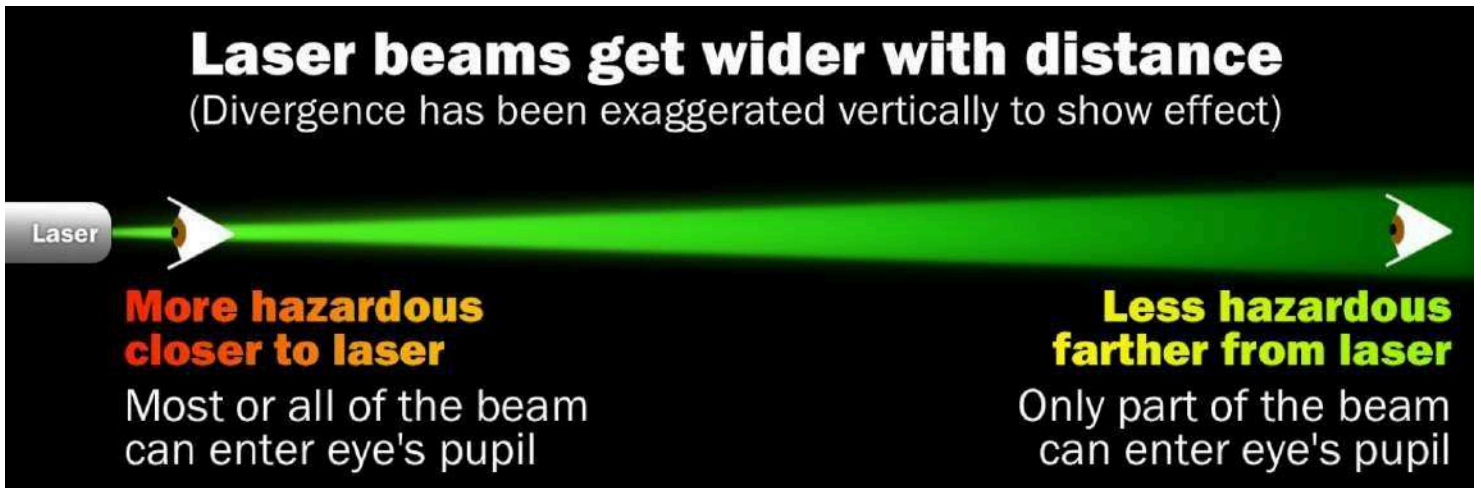

! For safety considerations, you should not use lasers to scan your audience if you are the operator.
If you are an audience, you should NEVER stare into a laser beam directly, avoid direct eyes and

For these actual high-powered WP50, WP70 laser systems herein, we'd like to provide some intuitive data for safety reference.

Nominal Ocular Hazard Distance(NOHD)

Laser beams slowly spread out. At the Nominal Ocular Hazard Distance (NOHD), the beam has spread enough so that the light intensity (irradiance) directly entering the eye is at the Maximum Permissible Exposure (MPE).

According to the beam diameter and divergence of WP50, WP70, O100 and 150W their NOHD should be 1.9km to 2km.





Lasers could cause aviation accidents if lasers are improperly used. To help reduce the risk of laser strikes, you can: Be aware of the dangers of lasers and the laws against pointing them at

Tips: NM=Nautical Mile, 1NM≈1.9KM 1mW=0.001W, 1nW=0.001mW Laser Free Zone=LFZ=Laser Prohibited Area

Different countries may have relevant laws and regulations on the potential laser hazards to aviation, but the following laser use standards formulated by the U.S FAA should be of great reference significance to the global aviation field.

The U.S. FAA Critical Flight Zone extends horizontally 10 NM (19 km) around the airport, and extends vertically to 10,000 feet (3,000 m) above ground level.

The optional Sensitive Flight Zone is designated around special airspace needing bright-light protection. Not all airports will have a Sensitive Flight Zone around them.



The U.S. FAA Laser Free Zone extends horizontally 2 NM (3,700 m) from the centerline of all runways (two dark lines in this diagram) with additional 3 NM (5,560 m) extensions at each end of a runway. Vertically, the LFZ extends to 2,000 feet (610 m) above ground level.

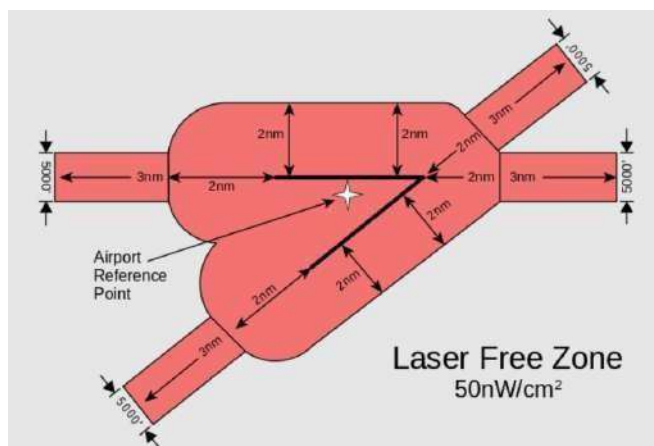

See the following reproductions of the product labels. All these labels must be intact and legible prior to be used on the projector.



Hazard warning symbol

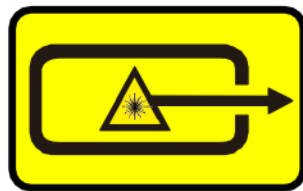

Aperture label



CE RoHS

LASER RADIATION
AVOID DIRECT EYE EXPOSURE
CLASS 4 LASER PRODUCT
DIN EN60825-1: 2015-07

CAUTION OF RADIATION
IF COVER IS MOVED

NEVER AIM AT AIRCRAFT, IT IS UNSAFE AND ILLEGAL
Compliance with IEC-EN60825-1 and 21 CFR 1010.10, 1040.11

Note:
Read user manual before use. Operation by qualified personnel only.
Never point laser beam at people. Never look into laser beam directly.
Any after sales services request, please contact your local authorized dealer or the direct seller for help.

Laser Wavelength(nm):
R 637 638
G 520 532
B 445 450 465

Total Power: _____W
Voltage AC: 100-120V 200-240V 100-240V 50-60Hz
Consumption: _____W
Year: _____

Brand: Optlaser
Model:
MADE IN CHINA

PROPER USAGE These products are for overhead mounting only. For safety purposes, this projector should be mounted on steady elevated platforms or sturdy overhead supports using suitable hanging clamps. In all cases, you must use safety cables. International laser safety regulations require that laser products must be operated in the fashion illustrated below, with a minimum of 3 meters (9.8 ft.) of vertical separation between the floor and the lowest laser light vertically. Additionally, 2.5 meters of horizontal separation is required between laser light and audience or other public spaces. The audience area can be passively protected by sliding the aperture cover plate upwards and fixing it in proper position by the two thumb screws.

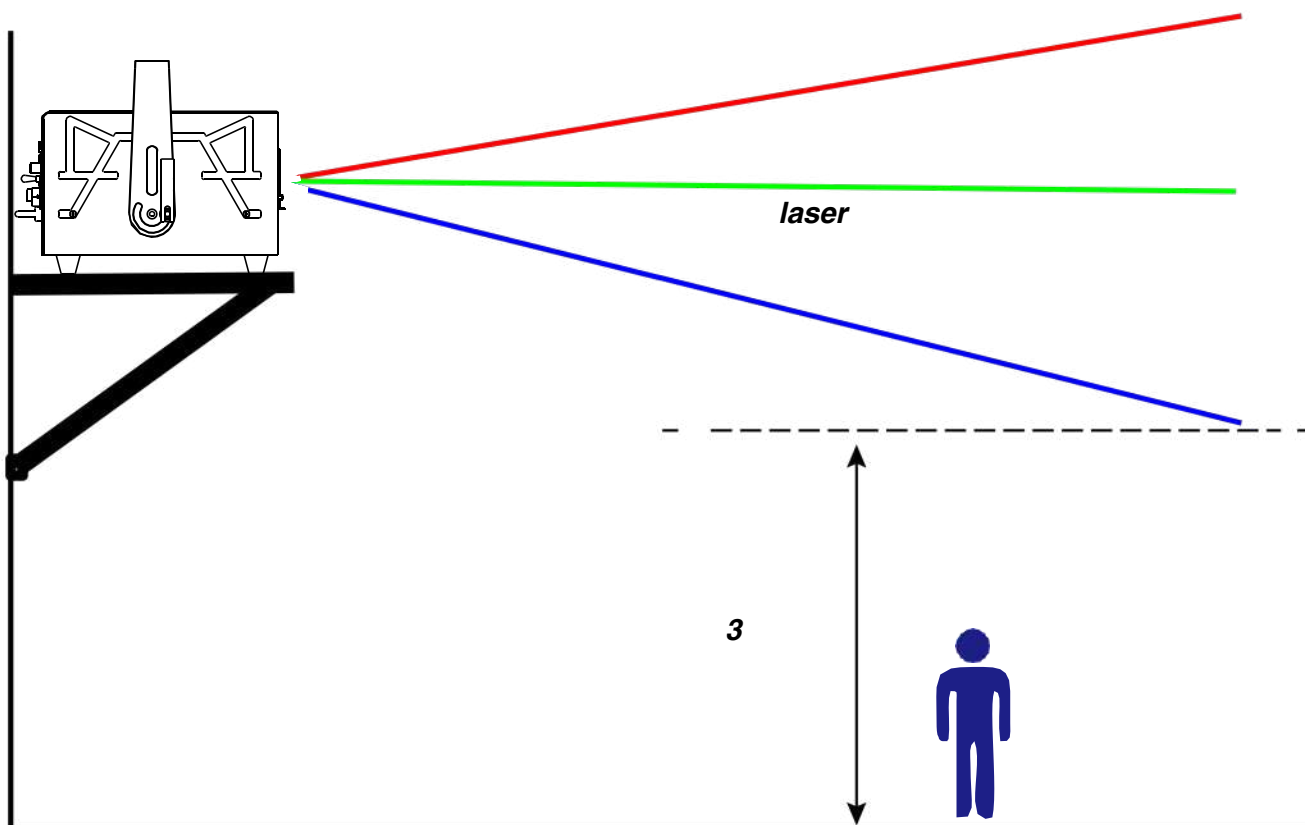

RIGGING

- Be sure that the structure onto which you are mounting this product can support its weight.
- Mount the product securely. You can do this with a screw, a nut, and a bolt. You may also use a mounting clamp if rigging this product onto a truss. The U-shaped support bracket has three mounting holes which may be used to secure the clamps to the projector.
- Always consider ease of access to the unit before deciding on a location for this product
- When mounting this product overhead, saalwfeatysusea

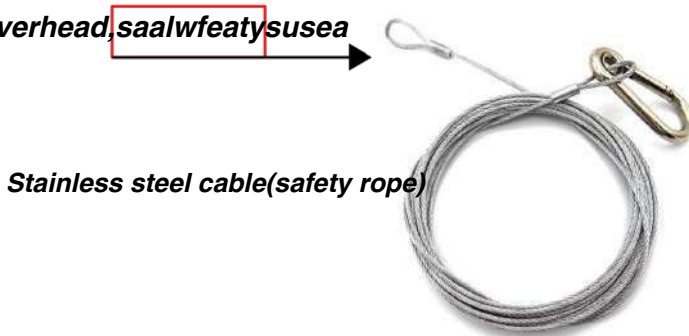

OPERATIONS WP SERIES units come with diode-based only laser sources and all

sources have beam

correction ,thus have great beam show with analog FULL colors modulation.

The PR SERIES units can be controlled over ILDA and have a built-in memory with preset patterns ,also with TF-card slot for freely programs export onto it, that can

be easily triggered by DMX. They can also be operated in automatic.

The laser projector provides a master-slave-mode. Show lasers of the same series (slave projectors), connected via DMX to a main projector (master projector) project the same patterns like the master projector.

This Series will be applicable for clubs, bars, and those Small/medium venues or theater events, parties, business activities, large venues etc.

“O series projectors are not supplied with standard "E-Stop Box" and "Remote Interlock bypass" Instead, a simplified “E-Stop Box” featured with “Mushroom switch” and “Key switch” will be supplied in the purchase accordingly to request.

The “E-stop Box” is generally with a CAT5 cable of 2m length unless there would be different requests.

If user doesn't need additional "E-Stop Switch", Then the “RJ45 jack interlock connector” should be inserted into the rear plate of the projector’s INTERLOCK position(with silkscreen marking) ,only by this way user will be able to light up the laser projector during operations.

Several steps to start up the laser projector(s)

1. Use the included power cord to connect the laser device to a proper power outlet(AC100-240V, 50/60Hz)

2. Use one of the included keys(2 sets included in the package, either one of them will work) to insert into the key-chassis and switch to the "ON" position

3. Use one of the the included INTERLOCK connectors to insert into the INTERLOCK position on the backplate of the device. (2 x RJ45 connectors(well made) included in the package

Remark: There are 2 positions for INTERLOCK on the backplate of the devices $\geq 10W$ herein, either one of the positions will work(one only position needs to be with INTERLOCK connector inserted if the laser projector

4. Turn on the power switch O to — , then the laser device from

Dual INTERLOCK ports |One port needs to be used with the connector unless you will use E-stop to daisy-chain.



INTERLOCK connector

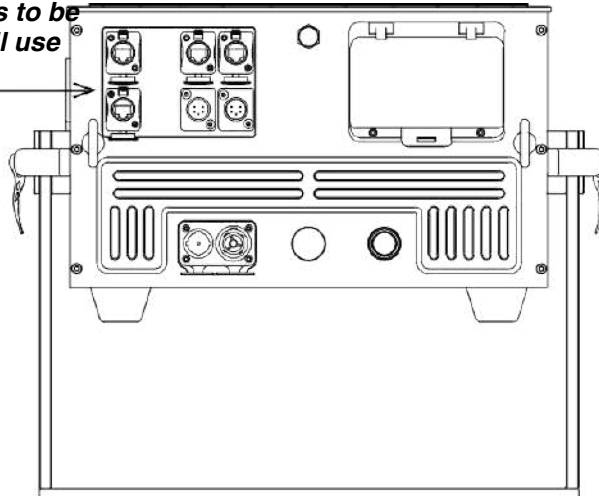

Emergency Stop Box



When Operation is with the E-stop box!



A: Use the supplied Neutrik powercon cable to connect the laser projector to a AC main power supply by using the input connector. Insert the safety keys(remain in the Off position).



B: To control the system by using an external signal e.g. ILDA or Ethernet(if FB4 built-in), plug the corresponding cable to the input connector at the back of the laser system.



C: Connect the E-stop box to the socket marked as INTERLOCK IN with a supplied CAT5/6 cable.



Remote interlock Bypass connector.



D: Insert the Remote interlock Bypass connector to the E-stop box and turn the key to on to disable the INTERLOCK (the US regulations).



E: Release the E-stop button by clockwise rotation, and the button will be pulled upwards.



F: Press down the START button on the E-stop box. Turn the keys and the power switch at the back of the laser system to the ON positions.



G: After the emission delay period of about 10-14s, the laser system is ready to start output laser emission by Enabling output thru laser software.

(Over these steps, the laser system is controlled by ILDA signal, in which way, make sure that the ILDA cable is well connected between the projector and the ILDA DAC controller which has to be well connected to the PC as well).

LCD Display Setting introductions

Indicators

a. Power supply and TF Card status indication:



OFF	Not powered
Slow flash	No TF Card
Always on	With TF Card

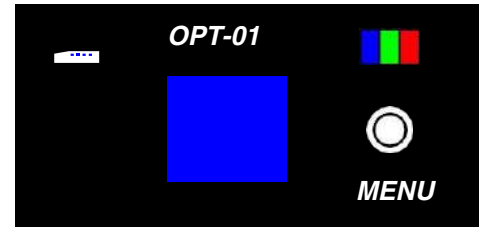

b. DMX status



OFF	Without DMX daughterboard Abnormal
Slow flash	DMX daughterboard loaded , but no DMX Signal

c. Laser Output status



OFF	No output
Always on	Normal output

Note:

All the contents listed on the LCD display can be freely changed to the preferable status. The most important step is to “double-click” the menu knob to SAVE the preferred status when all selections/settings get done. (The other settings should be operated step by step as DMX setting reference as the guidance following)

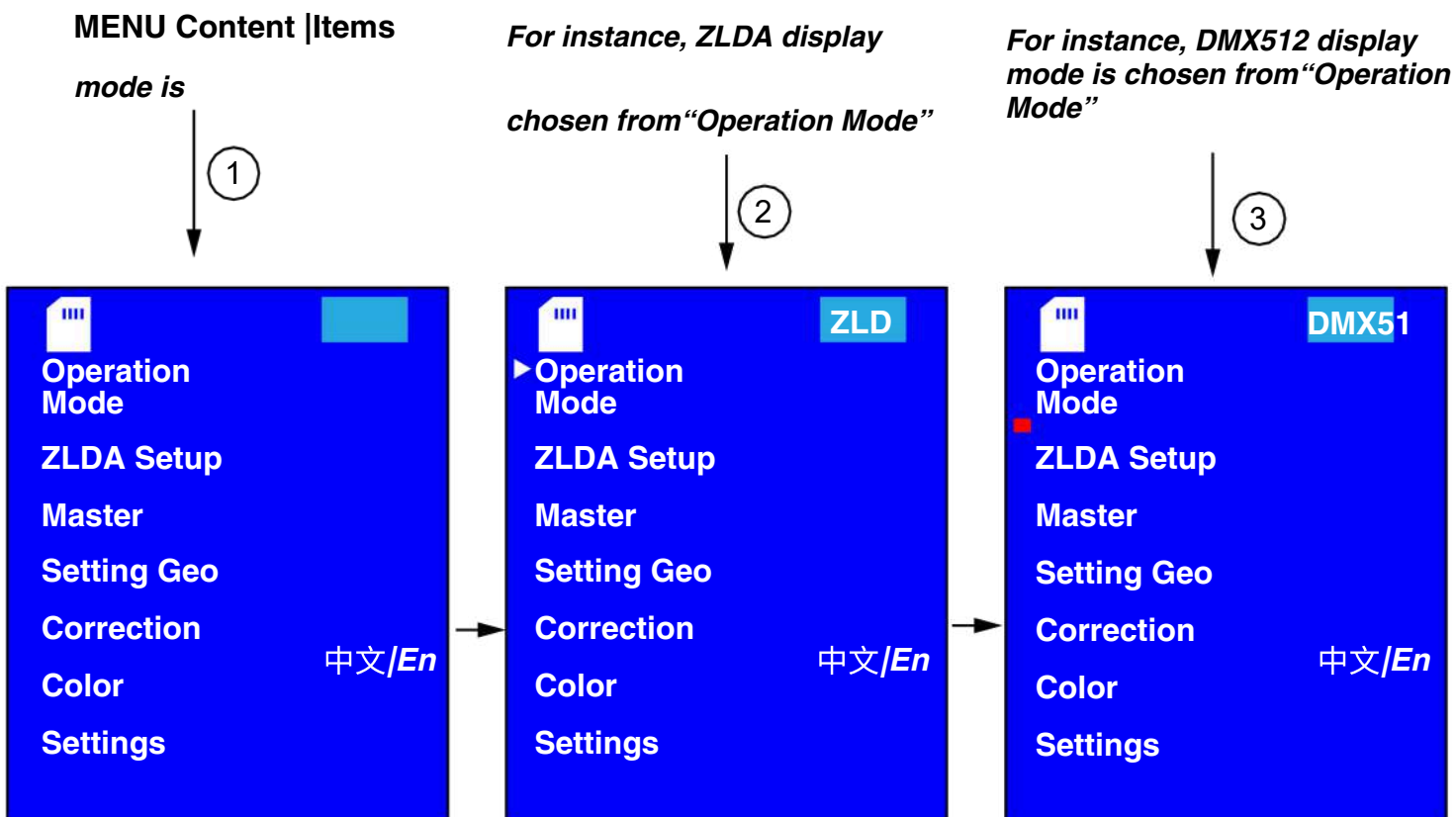

Remark area (the actual screen is without this colored background)

The real-time display mode status will be shown in this area, it can be any mode under the content Operation Mode such as ZILDA or DMX512, etc.

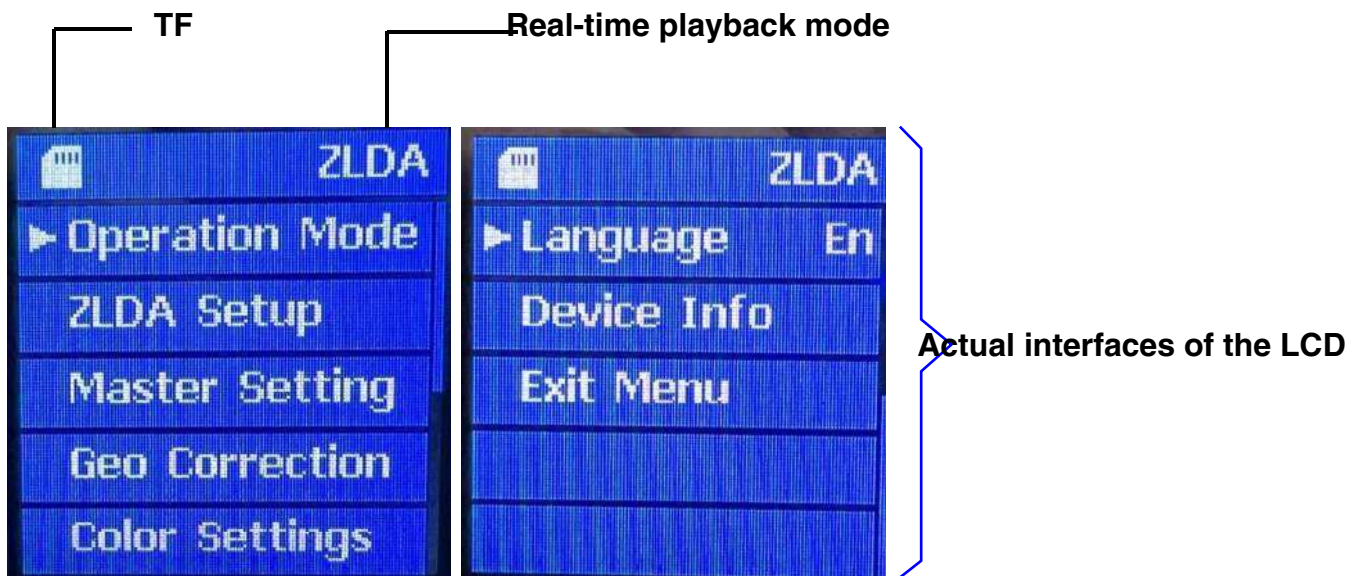

The Overall menu's content

	Operation Mode
	ZLDA Setup
	Master Setting
	Setting Geo
	Language <i>E</i>
	Device info
	Exit

Menu Item	Description
Operation Mode	Select the playback method, including [DMX512], [ILDA], [ZLDA], [TEST] and [DAC] and other playback mode
ZLDA Setup	Settings corresponding to the selected playback mode
Master Setting	Basic settings of the system
Geo Correction	Orientation parameter settings Geo correction
Color settings	Color parameter settings
Language	Chinese Simplified Chinese En English
Device Info	Device version and other information
Exit menu	Saves settings and turns off backlight

Master Setting

Master Setting	
Scan Rate Color	
Shift Rescan	
Each Play Turn	
Off Time	
Animate Mode 1	
Animate Rate 1	
Target FPS	
	1
0 Single Prt	
Interlock	
Exit	

Menu Item	Description	default value
Scan Rate	The number of points of laser output per second, range 5~40K	20
Color Shift	The number of points of the color lag coordinate, range 0~15 points	0
Rescan	After the playback source is disconnected, the duration before the program is turned off, unit millisecond, range 100~999ms	999
Each Play	The minimum playing time of each program, in seconds, range 1~20s	2
Turn Off Time	After there is no operation on the interface, the screen-off time, in seconds, ranges from 5 to 60s, 60s means the screen is always on	60
Animate Mode	1—display as per points 2—display as per frames	1
Animate Rate	This parameter is valid when display as per points is selected. 1	1

Selections of Operation Mode

Operation Mode	
DMX512	×
ILDA	×
Play	✓
ZLDA	×
Play	×
TEST	×
Play	

Menu Item	Description	default value
DMX512	DMX512 Control mode, program data comes from TF card, corresponding to the dmx\ directory ZLDA format file.	x
ILDAPlay	ILDA Play, program data comes from TF ILDA under the ilda\ directory in the card format file.	x
ZLDAPlay	ZLDA Play, program data comes from TF ZLDA under the zlda\ directory in the card format file.	x
TEST Play	TEST Play, program data comes from TF ZLDA in the test\ directory	x

Geo Correction

Geo	
Correction	
MXaSsctaelre	
Size	
100	
X Shear	
Y Shear	
Zangle	
X	
Position	X
Y	X
Position	X
X Invert	X
Y Invert	

Menu Item	Description	default value
Master Size	0~100%	50
XScale	0~100%	100
YScale	0~100%	100
XShear	-100~100%	0
YShear	-100~100%	0
ZAngle	0~359	0
XPosition	-100~100%	0
YPosition	-100~100%	0
XInvert	0 1 0-Positive,1-Reverse	x
YInvert	0 1 0-Positive,1-Reverse	x
XYSwap	0 1	x
Exit	Exitthecurrentmenuandreturntothepreviousmenu	

ZLDA Setup

Sub-menu

Play
Mode
File
Index
End
Action
Exit

Menu Item	Description	default value
Play mode	[Cue] Means only one laser cue will be displayed in loop, corresponding to ZLDA in the ildalcue\ directory format file . [List] Presents the playlist file, corresponding to ZLDA in the ildalist\001~999\ directory grid format file. [None] No output	single
FileIndex	Thenumberoffilescurrentlybeingplayed,from001to999.001 Select [Single] for playback mode, which means 001.zld~999.zld in the zldalcue\ directory Select [List] for the playback mode, which means the files in the 001\~999\ directory under the zldalist\ directory.	
EndAction	[Loop]Aftertheprogramreachestheend,itwillstart playing from the beginning. [Stop] After the program reaches the end, turn off the laser output.	cycle

Wiring guidelines for the LCD display[Mainboard]



Power connections

Pin	name	Voltage
1	GND	0
2	VCC	+7V ~ +24V

DMX input

Pin	name	Voltage
1	GND	0
2	DMXR _X	—
3	DMXT _x	—
4	I ₂ C SCL	—
5	I ₂ C SDA	—
6	I ₂ C V _{CC}	+3V
7	VCC	



ILDA Input

Pi	name	Voltage
n	GND	ground
1 2	HAS	ground
3 4	EN	0 ~ +5V
5 6	GND	~ +5V
7 8	BIN	+5V 0 -5V
9	GIN	~ +5V
10	RIN	-5V ~
11	GND	+5V -5V
12	YIN-	~ +5V
	YIN+	-5V ~
	XIN-	+5V
	XIN+	

RGB output

Pi	name	Voltage
n	Red	0 ~ +5V
1 2	Green	0 ~ +5V
3 4	Blue	0 ~ +5V
5	Deep Blue	0 ~ +5V
6	Yellow	0 ~ +5V
7	Cyan	0 ~ +5V
	Shutter	—

GS Output

Pi	name	Voltage
n	e Y+	-5V ~
1 2	Y-	+5V -5V
3 4	GND	~ +5V 0 0
5 6	GND	-5V ~
	X-	+5V -5V
	X+	~ +5V

50W SERIES

Standard Versions (without FB4 built-in)

Physical dimensions

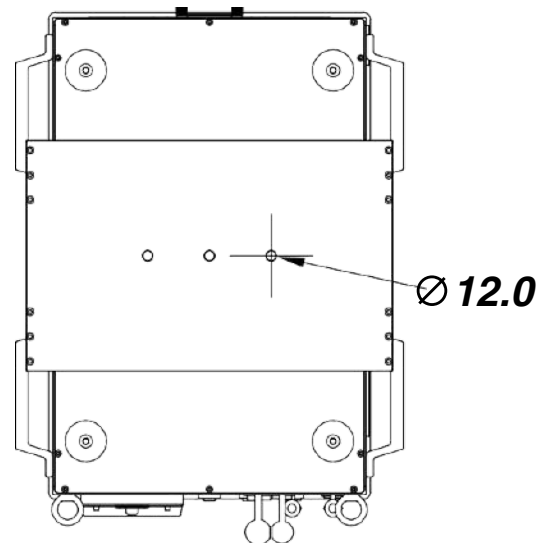
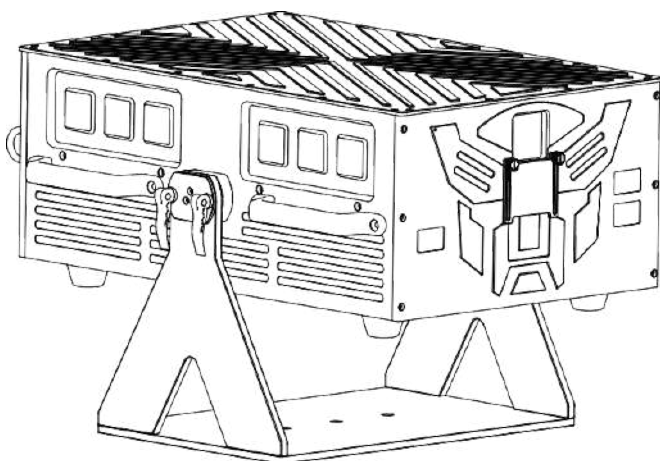
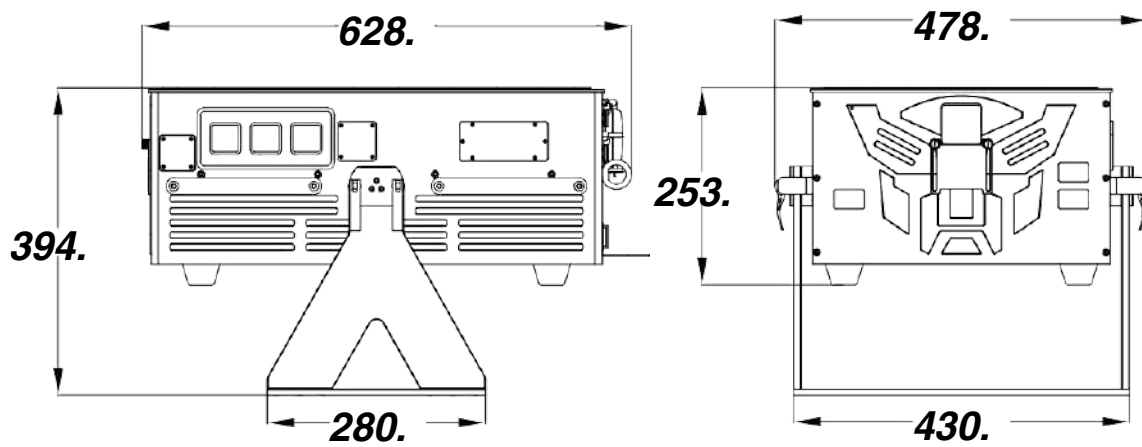

INTRODUCTIONS of WP50 SERIES

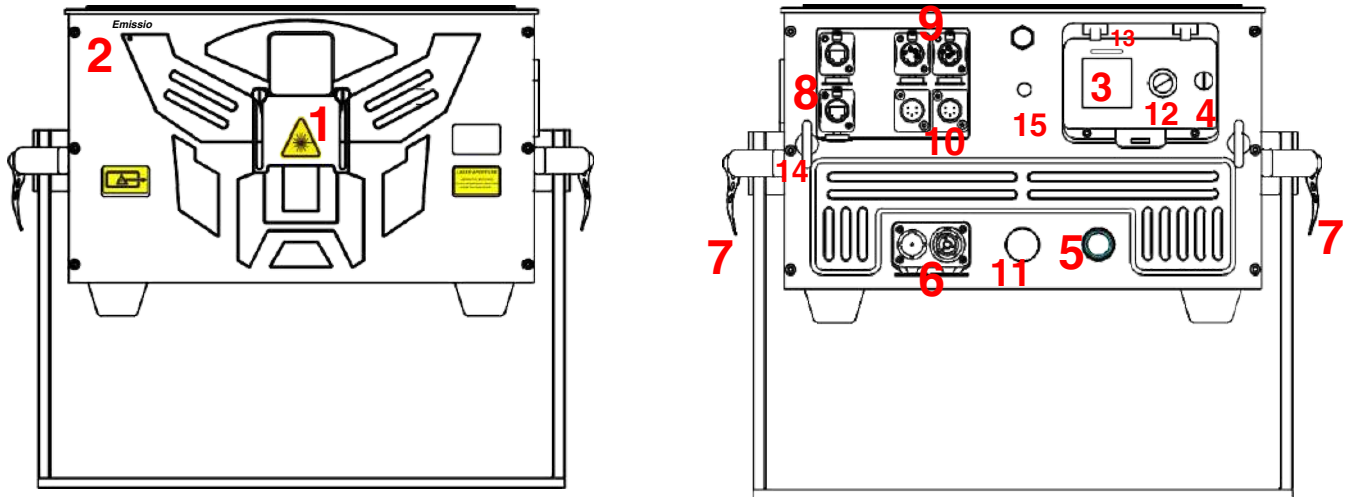

1	Laser aperture	<i>(covered by masking plate) DO NOT look directly into this aperture once the masking plate gets loosen</i>
2	Laser Emission	<i>When this indicator is lit up the laser system is ready to emit the laser radiation as soon as it receives instructions from control software.</i>
3	LCDDisplay	<i>Integrated with multi settings on the projector, please refer to detailed settings (on Page 11.) for the LCD</i>
4	Keyhole	<i>Safety key, laser output is available when the key is moved to position "on"</i>
5	Power Switch	<i>Power On/Off</i>
6	Power CON Input & Output	<i>Power connections input and output</i>
7	Swing/Rigging Screws	<i>For tightening or loosening the stand and then will let users to adjust a fittable projection angle</i>
8	INTERLOCK (RJ45 jack)	<i>Laser output is available only when the interlock is connected. It could be used to connect a laser emergency switch (E-stop box).</i>
9	ILDA Input & Output	<i>DB25 connector converted to 12 pin XLR input and output for ILDA mode display</i>
10	DMX Input & Output	<i>3-pin DMX connections input and thru for DMX512 mode display</i>
11	FUSE	<i>Safety element; current rating 8amps</i>
12	Menu knob for LCD Setting	<i>The knob for the main settings on LCD, click it to wake the LCD and rotate it for corresponding status setting</i>
13	SD-Card Slot	<i>Slot for SD-Card which you may have your own laser files to export on</i>
14	Safety Rings	<i>The rings for enwinding a safety rope when the laser device will be installed on out-of-reach locations.</i>
15	SFS	<i>Scan-fail safety switch</i>



Specifications of WP50 SERIES

Type of Laser	<i>Pure diode-based full colors(semiconductor diode laser systems)</i>												
Laser Classification	Class 4												
Laser Power(mW)	<table border="1"> <thead> <tr> <th>Model</th> <th>λ 638nm</th> <th>520nm</th> <th>445nm+465nm</th> </tr> </thead> <tbody> <tr> <td>60000-RGB</td> <td>R/18000mW+G/23000mW+B/23000mW</td> <td></td> <td></td> </tr> <tr> <td>70000-RGB</td> <td>R/18000mW+G/30000mW+B/27000mW</td> <td></td> <td></td> </tr> </tbody> </table>	Model	λ 638nm	520nm	445nm+465nm	60000-RGB	R/18000mW+G/23000mW+B/23000mW			70000-RGB	R/18000mW+G/30000mW+B/27000mW		
Model	λ 638nm	520nm	445nm+465nm										
60000-RGB	R/18000mW+G/23000mW+B/23000mW												
70000-RGB	R/18000mW+G/30000mW+B/27000mW												
Scanning-system	20kpps ILDA@8° , Scan angle Max 40°												
Beam Size@aperture	10*12 mm												
Beam Divergence	<0.95mRad												
Modulation	>100 KHz												
Power Supply	AC 100-240V, 50/60Hz												
Power Consumption	1000W 1300W												
Net Weight	48.50kg												
Dimension	628*430*253mm [excl. stand/bracket]												
Controls	Auto[ZLDA], DMX512 , ILDA												
Operation Temperature	minus 20°C to 40°C												
Protection Rating	IP65												
Safety elements	Interlock, emission delay, magnetic interlock, scan-fail safety, mechanical shutter, adjustable aperture masking plate.												
Important statement	Due to Advanced Optical Correction technology used in our laser systems the optical power output of each laser colour within the system may slightly differ from the specification of respective laser module(s) installed. This does not affect the total guaranteed power output.												

O100 SERIES

Standard Versions (without FB4 built-in)

Physical dimensions

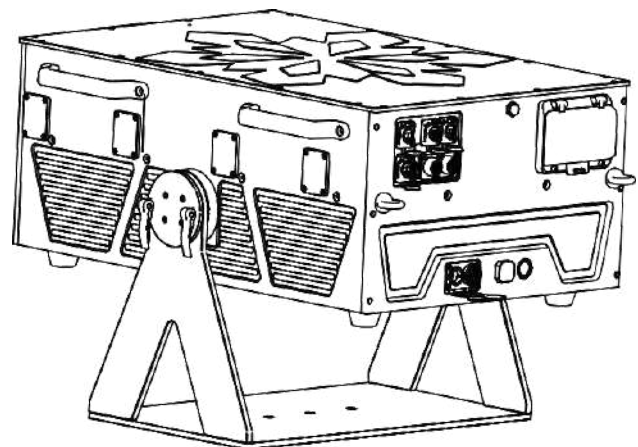
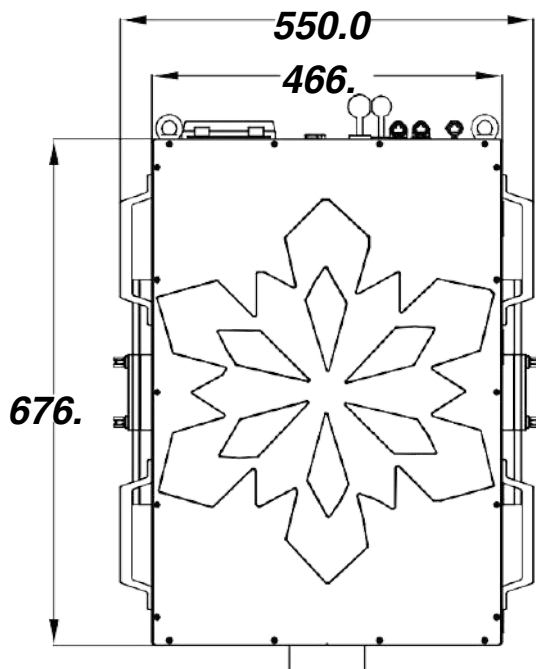
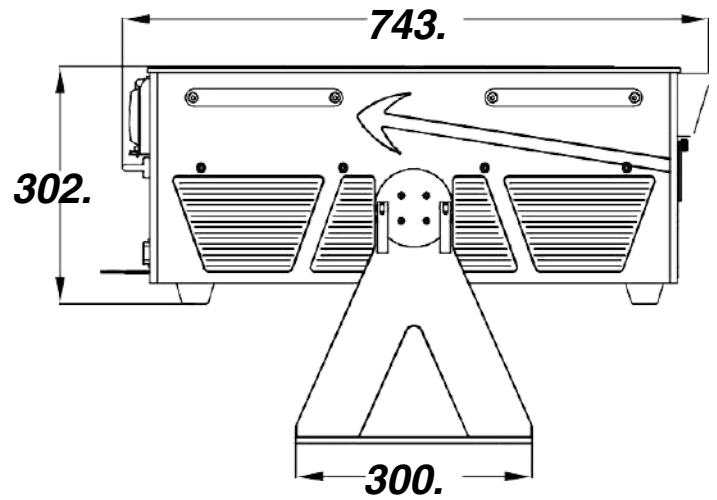
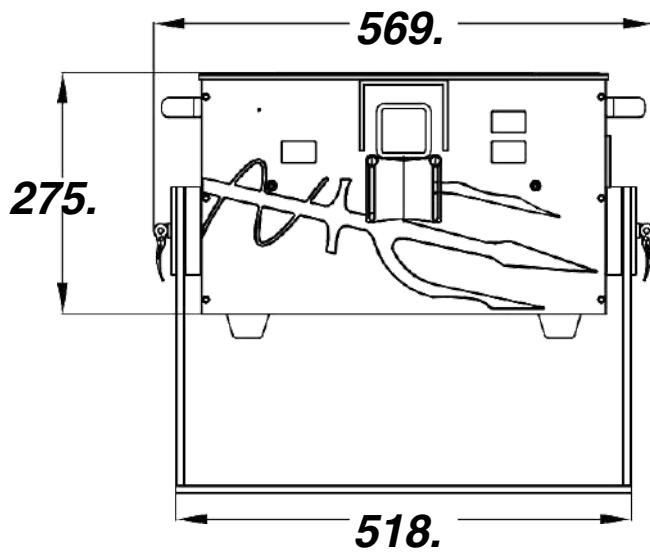

INTRODUCTIONS of O100 SERIES

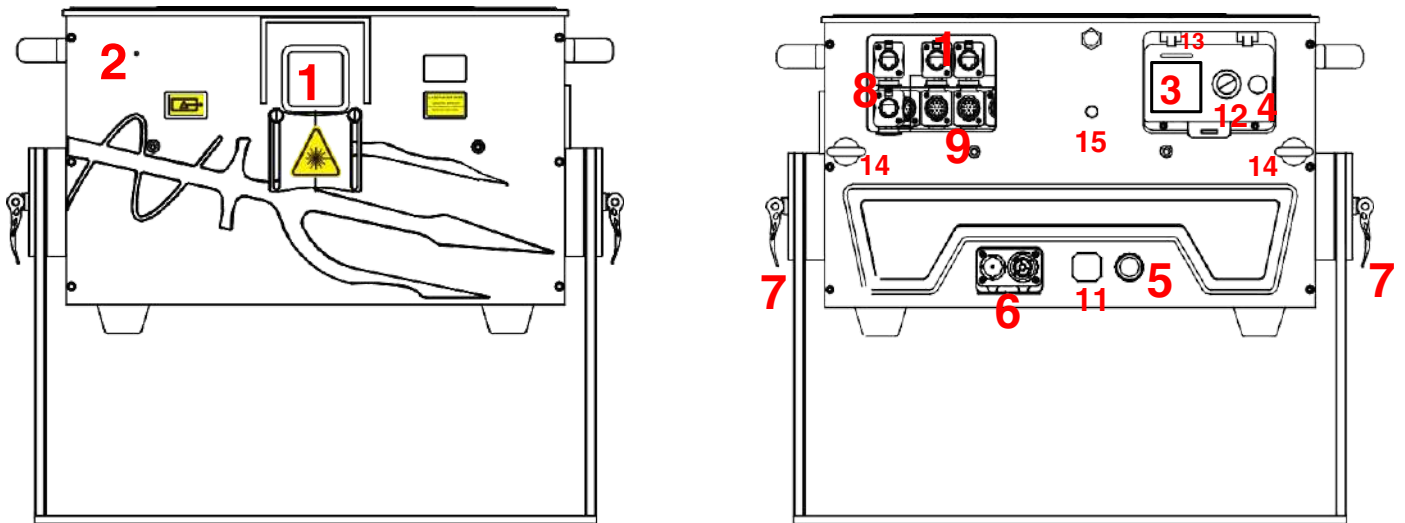

1	Laser aperture	<i>(covered by masking plate) DO NOT look directly into this aperture once the masking plate gets loosen</i>
2	Laser Emission	<i>When this indicator is lit up the laser system is ready to emit the laser radiation as soon as it receives instructions from control software.</i>
3	LCDDisplay	<i>Integrated with multi settings on the projector, please refer to detailed settings (on Page 11.) for the LCD</i>
4	Keyhole	<i>Safety key, laser output is available when the key is moved to position "on"</i>
5	Power Switch	<i>Power On/Off</i>
6	Power CON Input & Output Swing / Rigging Screws	<i>Power connections input and output</i>
7		<i>For tightening or loosening the stand and then will let users to adjust a fittable projection angle</i>
8	INTERLOCK (RJ45 jack)	<i>Laser output is available only when the interlock is connected. It could be used to connect a laser emergency switch (E-stop box).</i>
9	ILDA Input & Output	<i>DB25 connector converted to 12 pin XL R input and output for ILDA mode display</i>
10	DMX Input & Output	<i>3-pin DMX connections input and thru for DMX 512 mode display</i>
11	FUSE	<i>Safety element; current rating 8amps</i>
12	Menu knob for LCD Setting	<i>The knob for the main settings on LCD, click it to wake the LCD and rotate it for corresponding status setting</i>
13	SD-Card Slot	<i>Slot for SD-Card which you may have your own laser files to export on</i>
14	Safety Rings	<i>The rings for enwinding a safety rope when the laser device will be installed on out-of-reach locations.</i>

★ Specifications of O100 SERIES

Type of Laser	<i>Pure diode-based full colors(semiconductor diode laser systems)</i>																									
Laser Classification	Class 4																									
Laser Power(W)	<table border="1"> <thead> <tr> <th>Model</th> <th>λ</th> <th>638nm</th> <th>520nm</th> <th>445nm or 465nm</th> </tr> </thead> <tbody> <tr> <td>O100000-RGB</td> <td></td> <td>R/35W</td> <td>G/35W</td> <td></td> </tr> <tr> <td></td> <td></td> <td>B/36W</td> <td>WP140000-RGB</td> <td></td> </tr> <tr> <td></td> <td></td> <td>R/38W</td> <td>G/48W</td> <td></td> </tr> <tr> <td></td> <td></td> <td>B/54W</td> <td></td> <td></td> </tr> </tbody> </table>	Model	λ	638nm	520nm	445nm or 465nm	O100000-RGB		R/35W	G/35W				B/36W	WP140000-RGB				R/38W	G/48W				B/54W		
Model	λ	638nm	520nm	445nm or 465nm																						
O100000-RGB		R/35W	G/35W																							
		B/36W	WP140000-RGB																							
		R/38W	G/48W																							
		B/54W																								
Scanning-system	20kpps ILDA@8° , Scan angle Max 40°																									
Beam Size@aperture	10*12 mm																									
Beam Divergence	<0.95 mRad																									
Modulation	>100 KHz																									
Power Supply	AC 100-240V, 50/60Hz																									
Power Consumption	1700 2000																									
Net Weight	79.90kg																									
Dimension	744*466*302mm [excl. stand/bracket]																									
Controls	Auto[ZLDA], DMX512 , ILDA [FB4 on request]																									
Operation Temperature	minus 20°Cto 40°C																									
Protection Rating	IP65																									
Safety elements	Interlock, emission delay, magnetic interlock, scan-fail safety, mechanical shutter, adjustable aperture masking plate.																									
Important statement	Due to Advanced Optical Correction technology used in our laser systems the optical power output of each laser colour within the system may slightly differ from the specification of respective laser module(s) installed. This does not affect the total guaranteed power output.																									

150W SERIES

Standard Versions (without FB4 built-in)

Physical dimensions

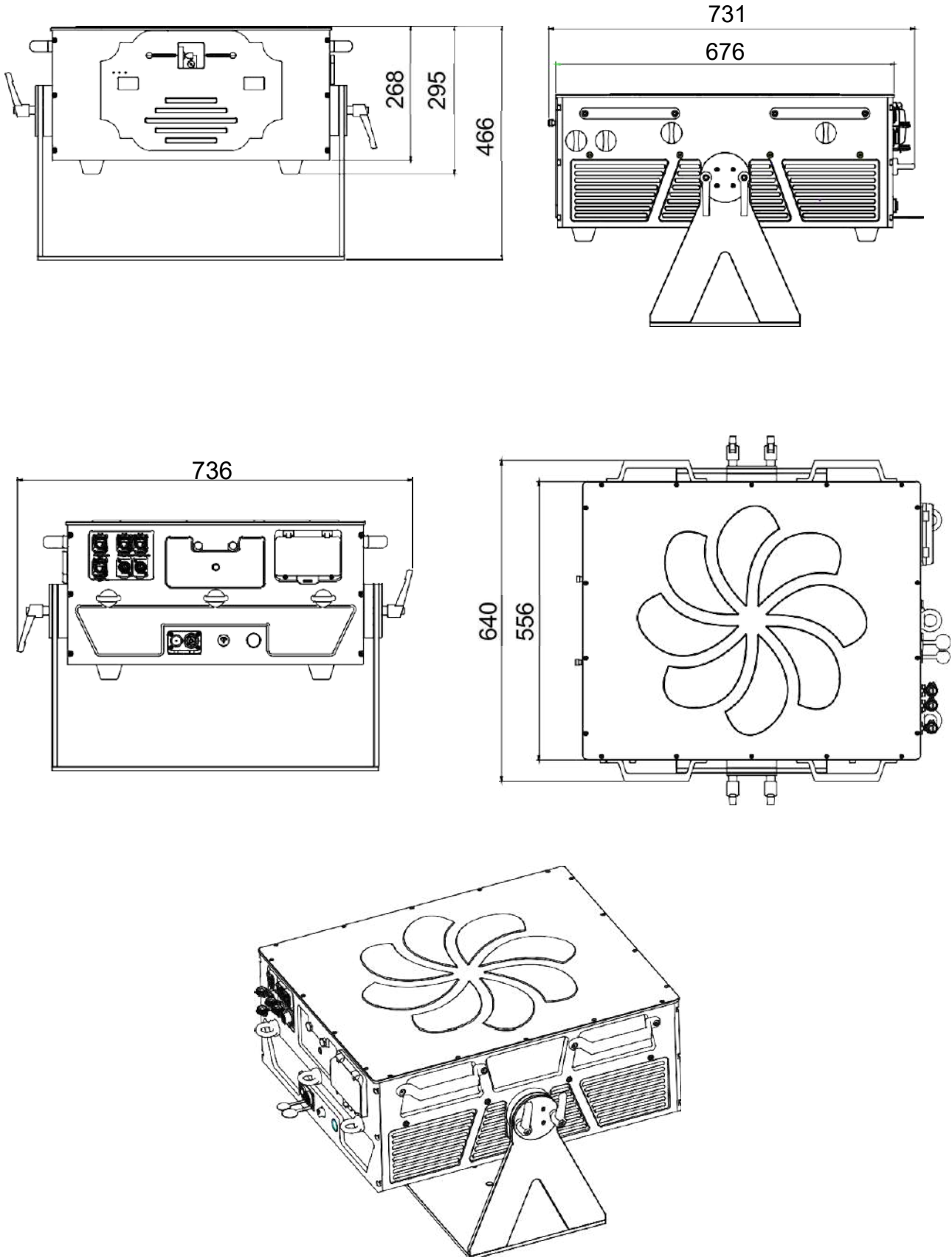

INTRODUCTIONS *of* 150W SERIES

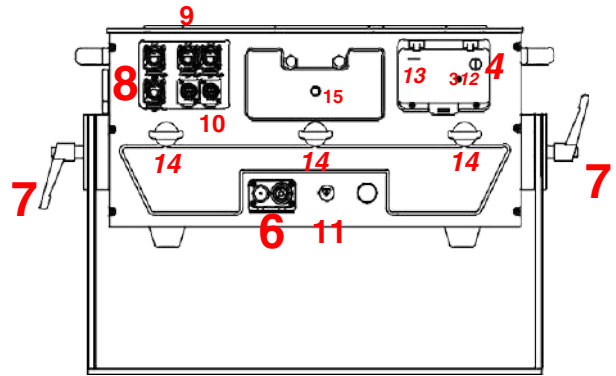
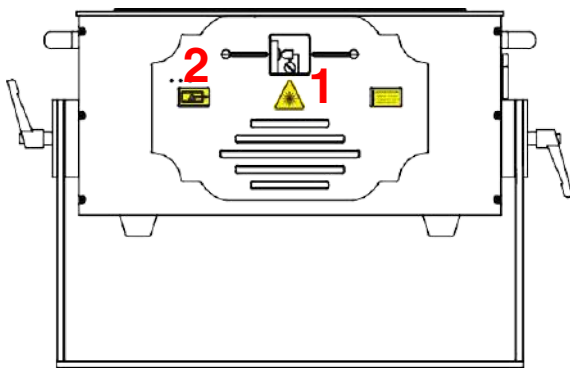

1	Laser aperture	<i>(covered by masking plate) DO NOT look directly into this aperture once the masking plate gets loosen</i>
2	Laser Emission	<i>When these indicators are lit up the laser system is ready to emit the laser radiation as soon as it receives instructions from control software.</i>
3	LCDDisplay	<i>Integrated with multi settings on the projector, please refer to detailed settings (on Page 11.) for the LCD introductions.</i>
4	Keyhole	<i>Safety key, laser output is available when the key is moved to position "on"</i>
5	PowerSwitch	<i>Power On/Off</i>
6	Power CON Input & Output	<i>Power connections input and output</i>
7	Swing /tightening Screws	<i>For tightening or loosening the stand and then will let users to adjust a fittable projection angle</i>
8	INTERLOCK (RJ45 jack)	<i>Laser output is available only when the interlock is connected. It could be used to connect a laser emergency switch (E-stop box).</i>
9	ILDA Input & Output	<i>DB25 connector converted to 12 pin XLR input and output for ILDA mode display</i>
10	DMX Input & Output	<i>3-pin DMX connections input and thru for DMX 512 mode display</i>
11	FUSE	<i>Safety element; current rating 8amps</i>
12	Menu knob for LCD Setting	<i>The knob for the main settings on LCD, click it to wake the LCD and rotate it for corresponding status setting</i>
13	SD-Card Slot	<i>Slot for SD-Card which you may have your own laser files to export on</i>
14	Safety Rings	<i>The rings for enwinding a safety rope when the laser device will be installed on out-of-reach locations.</i>
15	SFS	<i>Scan-fail safety switch</i>

★ Specifications of 150W SERIES

Type of Laser	<i>Pure diode-based full colors(semiconductor diode laser systems)</i>																									
Laser Classification	Class 4																									
Laser Power(W)	<table border="1"> <thead> <tr> <th>Model</th> <th>λ</th> <th>638nm</th> <th>520nm</th> <th>445nm or 465nm</th> </tr> </thead> <tbody> <tr> <td>150W000-RGB</td> <td></td> <td>R/43W</td> <td>G/53W</td> <td></td> </tr> <tr> <td></td> <td></td> <td>B/80W</td> <td>WP200000-RGB</td> <td></td> </tr> <tr> <td></td> <td></td> <td>R/50W</td> <td>G/75W</td> <td></td> </tr> <tr> <td></td> <td></td> <td>B/85W</td> <td></td> <td></td> </tr> </tbody> </table>	Model	λ	638nm	520nm	445nm or 465nm	150W000-RGB		R/43W	G/53W				B/80W	WP200000-RGB				R/50W	G/75W				B/85W		
Model	λ	638nm	520nm	445nm or 465nm																						
150W000-RGB		R/43W	G/53W																							
		B/80W	WP200000-RGB																							
		R/50W	G/75W																							
		B/85W																								
Scanning-system	15kpps ILDA@8° , Scan angle Max 40°																									
Beam Size@aperture	14*16 mm																									
Beam Divergence	<0.95 mRad																									
Modulation	>100 KHz																									
Power Supply	AC 100-240V, 50/60Hz																									
Power Consumption	2700 2900W																									
Net Weight	89.90kg																									
Dimension	731*640*295mm [excl. stand/bracket]																									
Controls	Auto[ZLDA], DMX512 , ILDA [FB4 on request]																									
Operation Temperature	minus 20°C to 40°C																									
Protection Rating	IP65																									
Safety elements	Interlock, emission delay, magnetic interlock, scan-fail safety, mechanical shutter, adjustable aperture masking plate.																									
Important statement	Due to Advanced Optical Correction technology used in our laser systems the optical power output of each laser colour within the system may slightly differ from the specification of respective laser module(s) installed. This does not affect the total guaranteed power output.																									

DMX Charts

16 CHs

CH	Value	Descriptions	Width
1	0-255 DMXmodel –	0-31_ Closetlight 33-95_ Top8 97-159_ Top8 161-232_ Top 12 225-255_ Top 16 channels	8Bit
2	0-255 Pageindex – (9 in total Page)	0-15_ Page1 17-31_ Page2 33-47_ Page3 49-63_ Page4 65-79_ Page5 81-95_ Page6 97-111_ Page7 113-127_ Page 8 129-255_ Page 9	8Bit
3	0-255 program – index (48 in total programme)	0-32_ Closethe light 33-35_ Program 1 37-39_ Program2 221-223_ Program 48 225-255_ — —	8Bit
4	0-255 speed –	0-15_ Default speed 17-31_ pause 33-255_ 25%~200%	8Bit
5	0-255 brightness	0% ~ 100%	8Bit
6	0-255 size	0%~ 100%	8Bit
7	0-255 Xsize	-100% ~ 100%	8Bit
8	0-255 Ysize	-100% ~ 100%	8Bit
9	0-255 Zangle	0~360 deg	8Bit
10	0-255 Xposition	0 = left , 128 = center , 255 = right	8Bit
11	0-255 Yposition	0 = top , 128 = mid , 255 = bottom	8Bit
12	0-255 Visiblepoint	0 ~ 100%	8Bit
13	0-255 scanrate –	0-31_ Defaultscan rate 33-223_ 6K ~ 29K 225-255_ 30K	8Bit
14	0-255 reserve –		8Bit

15	0-255 <i>color table</i>	0-31 <i>original color 33-223 table</i> 225- 255 <i>white</i>	<i>8Bit</i>
16	0-255 <i>Reserved</i>	<i>Reserved</i>	<i>8Bit</i>

26 CHs

CH	Value	Description	Width
1	0-255 page index	pageindex, 0~3 lightoff 4~7 No.1 Page8~ 112nd Page12~15 No. 3 Page ... 252~255 No.63Page	8Bit
2	0-255 program index	programindex 0~3 light off 4~7 No.1 programme 8~ 11 2nd programme 12~15 No.3 programme ... 252~255 No.63programme	8Bit
3	0-255 playback speed	(0=originalspeed,1-255=1%~ 255%)	8Bit
4	0-255 brightness _	(0~100%)	8Bit
5,6	0-65535 size	(0~100%)	16Bit
7,8	0-65535X _size	(-100~100%,0=32768)	16Bit
9,10	0-65535 Ysize	(-100~100%,0=32768)	16Bit
11,12	0-65535 Zangle	Rotationangle(0~360°)	
13,14	0-65535Z _rotate	Rotation speed -60 ~ 60 Rpm (0 = original position , 1 ~ 32767 = -100% ~ -1 % Rotation speed , 32768 = Save stationary and not rotating , 32769 ~ 65535 = 1% ~ 100% Rotating speed)	
15,16	0-65535X _Location	(-100~100%,0=32768)	16Bit
17,18	0-65535 YLocation	(-100~100%,0=32768)	16Bit
19	0-255 scan rate	(5k~30K)	8Bit
20	0-255 red light brightness	(0~100%)	8Bit
21	0-255 green light brightness	(0~100%)	8Bit
22	0-255 blue light brightness	(0~100%)	8Bit
23	0-255 RGB _ Change color	(0 = original color , 1-255 = 0 ~ 100% color change)	8 Bit
2	0-255 start display points	(0~100%)	8Bit
4	0-255end displaypoint	(0~100%)	8Bit
2	0-255 strobe _	0=Turnoffstrobe	8Bit
5		1-255 = 1 to 20 Hz	

CH	Value	Description	Width
1	0-255playmode	0-150lightoff 150-190 setting mode 200-240 playback mode 240-255light	8Bit
2	0-255maximumbrightness	Definesthemaximumbrightnessusedin playback mode (0 ~ 100%)	8Bit
3	0--255testpattern	(1=testprogram1,255=testprogram 255)	8Bit
4,5	0-65535X _size	Definesthemaximumwidthusedin playback mode (-100 ~ 100%, 0 = 32768)	16Bit
6,7	0-65535Y_ size	Definesthemaximumheight used in playback mode (-100 ~ 100%, 0 = 32768)	16Bit
8,9	0-65535X _Location	Definethehorizontalpositioninplayback mode (-100 ~ 100%, 0 = 32768)	16Bit
10,11	0-65535 YLocation	Definestheverticalpositioninplayback mode (-100 ~ 100%, 0 = 32768)	16Bit
12,13	0-65535 ZRotationangle	Definetherotationangleinplaymode(0~ 360 °)	16Bit
14	0-255pageindex	Pageindex,1=page1Page,255= Page 255 Page	8Bit
15	0-255programindex	Programindex,(1=1stprogram,255= 255th _ programme)	8Bit
16	0-255playbackspeed	(0=originalspeed,1-255=1%~ 255%)	8Bit
17	0-255brightness_	(0~100%)	8Bit
18,19	0-65535 size	(0~100%)	16Bit
20,21	0-65535X _size	(-100~100%,0=32768)	16Bit
22,23	0-65535 Ysize	(-100~100%,0=32768)	16Bit
24,25	0-65535Z _angle	Rotationangle(0~360°)	16Bit
26,27	0-65535 Zrotate	Rotationspeed-60~60Rpm(0= original position , 1 ~ 32767 = -100% ~ -1 % Rotation speed , 32768 = Save stationary and not rotating , 32769 ~ 65535 = 1% ~ 100% Rotating speed)	16Bit
28,29	0-65535X _Location	(-100~100%,0=32768)	16Bit
30,31	0-65535 YLocation	(-100~100%,0=32768)	16Bit
32	0-255scanrate	(5k~30K)	8Bit
33	0-255redlightbrightness	(0~100%)	8Bit
34	0-255greenlightbrightness	(0~100%)	8Bit
35	0-255bluelightbrightness	(0~100%)	8Bit
36	0-255RGB_Changecolor	(0=originalcolor,1-255=0~100% color change)	8Bit

3	0-255 start display points	(0 ~ 100%)	8Bit
7	0-255end displaypoint	(0 ~ 100%)	8Bit
3	0-255 strobe _	0 = Turn off strobe	8Bit
8		1-255 = 1 to 20 Hz	

3

9

Maintenance Instruction

The device is mostly installed in the location that there is dust, haze, and smoke, which are easily pollute the lens and decrease the output brightness; these particles also easily pollute the light case, fans, PCBA, block the heat dissipation, and reduce the stability of the electronic components; so the regular cleaning is very necessary and important to keep the maximum light output and increase the stability and lifetime.

It is recommended to clean the window lens, outside case, and fans every 2 weeks, and clean the internal of the stage light every 4 weeks; the cleaning frequency should be higher in the severe working condition.

Note:

Only an qualified & authorized technician(s) is(are) allowed to clean the internal parts, improper operations for the internal cleaning could cause serious damage to the device. It is forbidden to use the corrosive chemicals to clean the device, the pure alcohol and acetone is recommended to clean the lens.

Clean the lens carefully and gently, don't touch the lens by any hard and sharp materials.

After sales service and warranty

**** One year's warranty for the device.***

**** The components and accessories costs are charged after the warranty period.***

****Warranty voids for the damages or injuries caused by force majeure, like, earthquake, typhoon, and so on.***

****Warranty voids for the damages or injuries caused by improper operation and projection, such as wrong input voltage, water immerse, physical shock, and so on***